

List of Part

Part #	Code	Description	Material Spec	Size	Qty.	Unit	Total
1	901-040-0070-4	6(+/-0.35)mmT x 1500 x 3000 Hot Rolled Steel Sheet	SS400 JIS G3101	153x25x6mm	1	Sheet	0.0013
2	901-040-0070-4	6(+/-0.35)mmT x 1500 x 3000 Hot Rolled Steel Sheet	SS400 JIS G3101	49.4x29.9x6mm	2	Sheet	0.0010

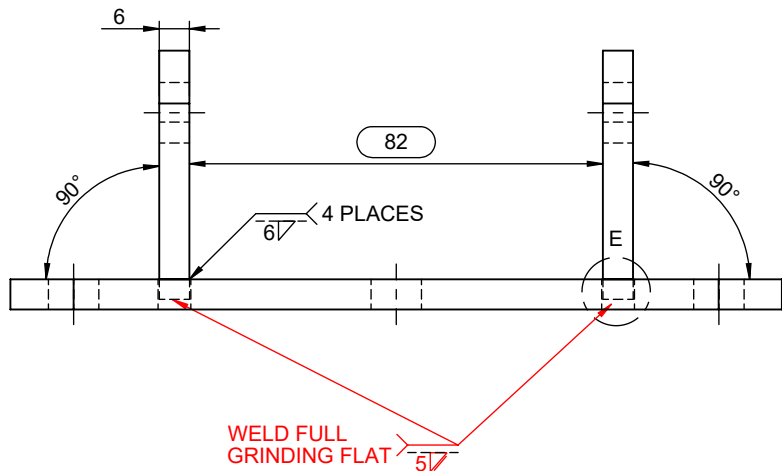

DETAIL E  
SCALE 2.5 : 1

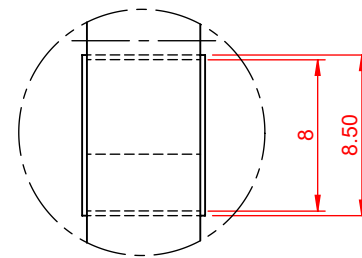
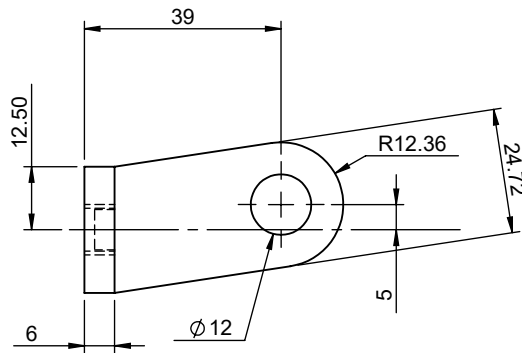
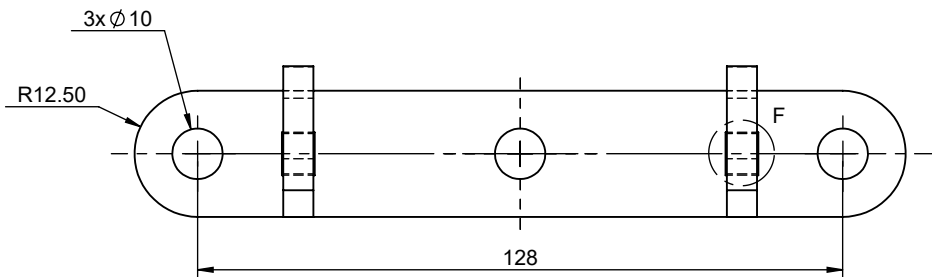
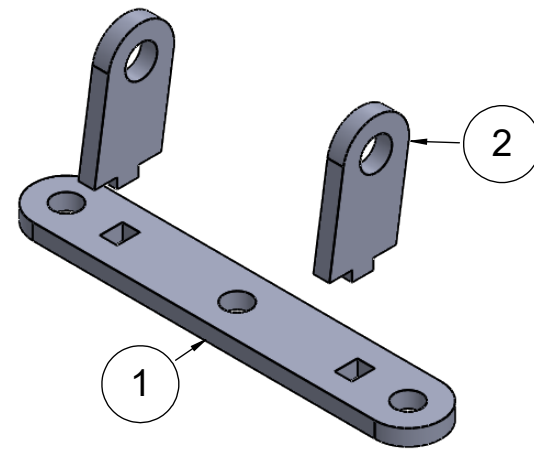
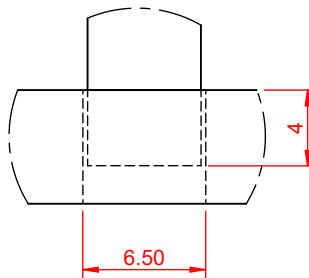

DETAIL F  
SCALE 2.5 : 1

Note:

- Không để bavia và cạnh bén nhọn